



**SUBARU**

PART NUMBER: 35160AL00A

INSTALLATION  
INSTRUCTIONS

DESCRIPTION:  
LEATHER TRIMMED SHIFT KNOB

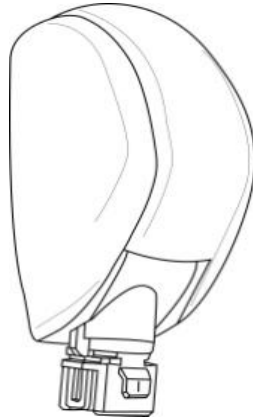

LEATHER TRIMMED SHIFT KNOB

**TOOLS REQUIRED:**

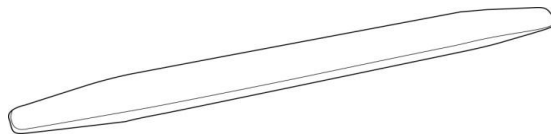

PLASTIC TRIM REMOVAL TOOL

**PART IDENTIFICATION:**

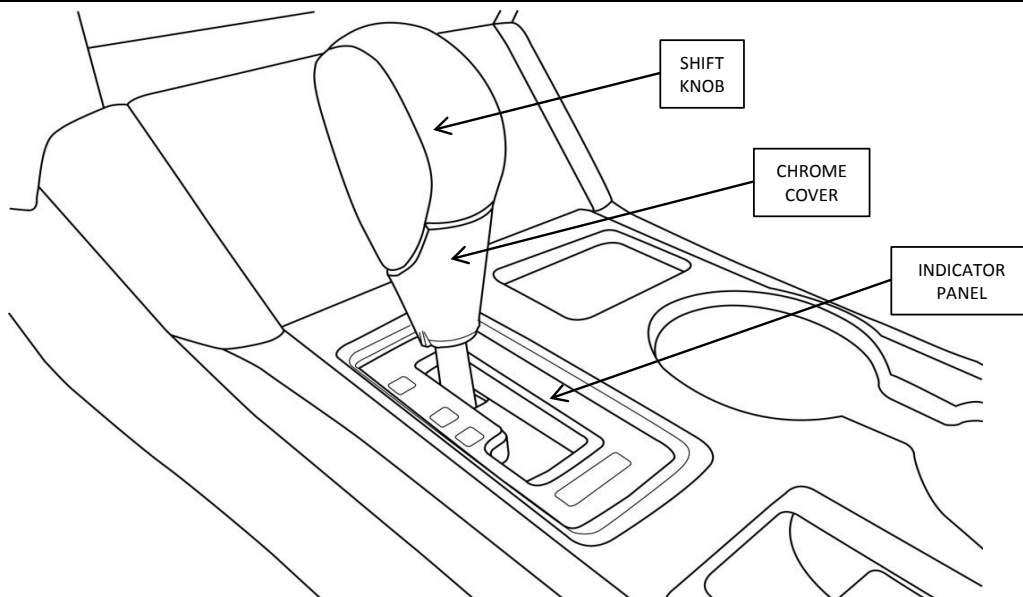

PART NUMBER:  
35160AL00A

ISSUE  
01

4/24/2014

SUBARU OF AMERICA

PAGE  
1/5



**STEP 1:** TURN IGNITION OFF, SHIFT LEVER TO "P" AND ENGAGE PARKING BRAKE. PLACE A SOFT PAD UNDER THE CHROME COVER TO PREVENT ANY DAMAGE TO THE INDICATOR PANEL DURING REMOVAL. USE THE PLASTIC TRIM REMOVAL TOOL TO GENTLY PRY THE CHROME COVER DOWNWARD. **TIP:** SEE THE STAR SYMBOLS FOR POTENTIAL DAMAGE/CONTACT POINTS.

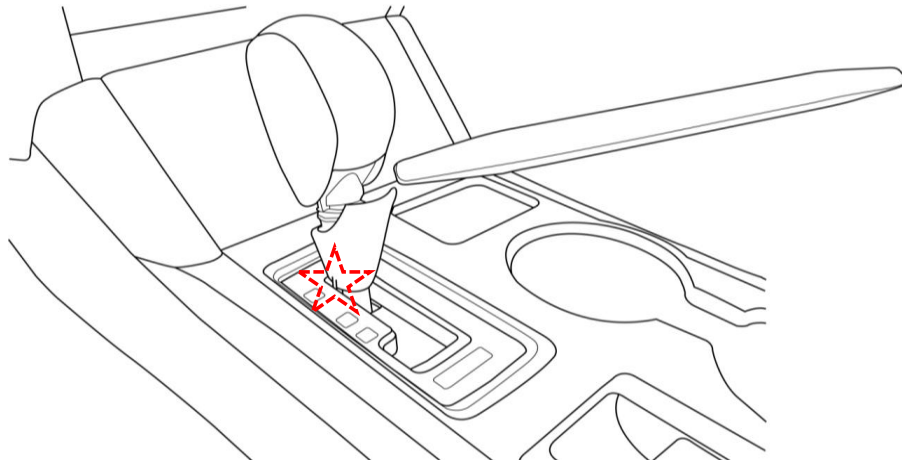

**STEP 2:** ROTATE THE CHROME COVER TO PROVIDE ACCESS TO THE RETENTION CLIP.

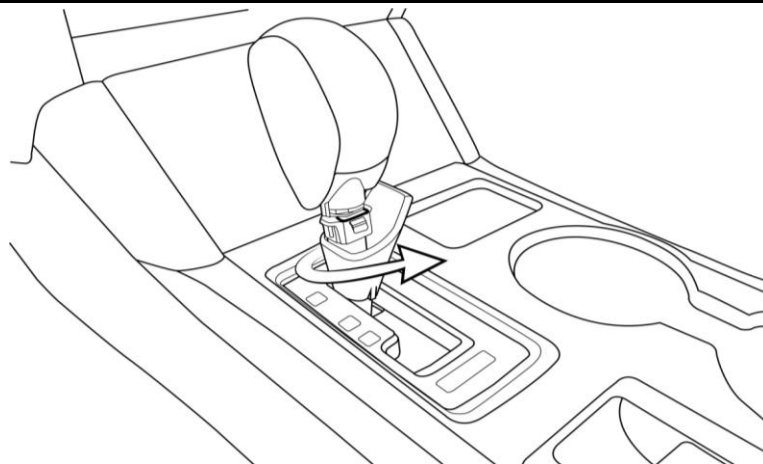

**STEP 3:** NOTE THE LOCATION AND ORIENTATION OF THE RETENTION CLIP THEN REMOVE IT. PULL THE RETENTION CLIP TOWARDS THE REAR OF THE VEHICLE.

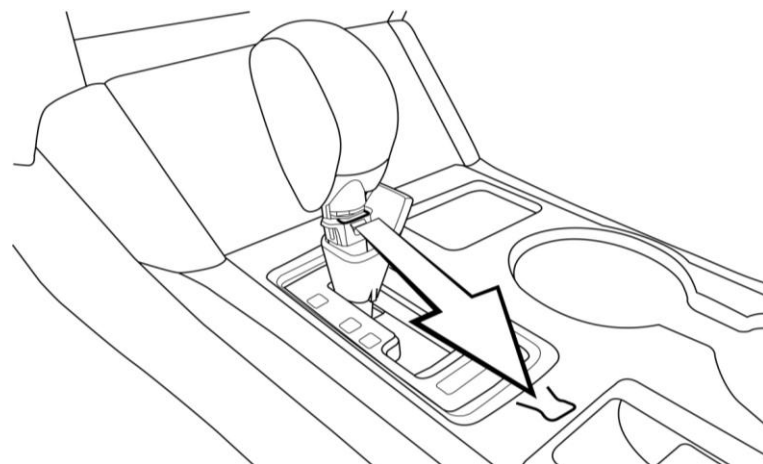



**SUBARU**

PART NUMBER: 35160AL00A

**STEP 4: LIFT UPWARDS TO REMOVE THE SHIFT KNOB. CAUTION: DO NOT REMOVE SHIFTER ROD. IF SHIFTER ROD IS REMOVED ACCIDENTALLY, PLEASE REFER TO PAGE 5 FOR PROPER RE-INSTALLATION.**

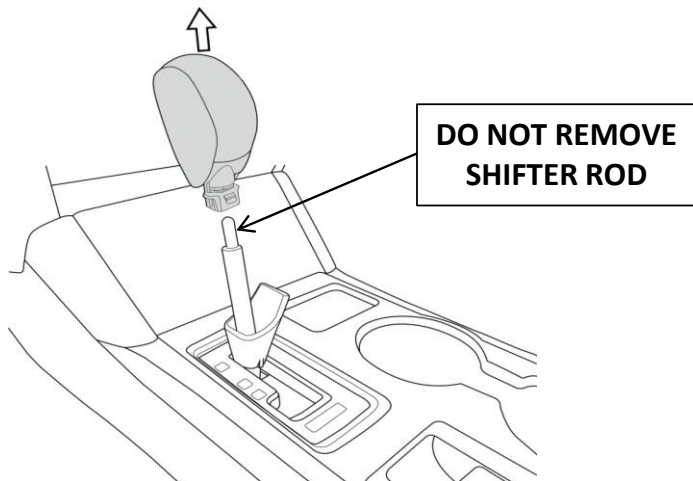

**STEP 5: INSERT NEW SHIFT KNOB.**

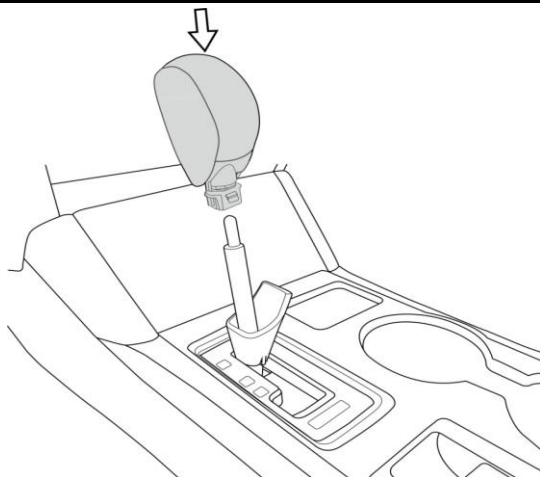

**STEP 6: INSERT RETENTION CLIP AS SHOWN.**

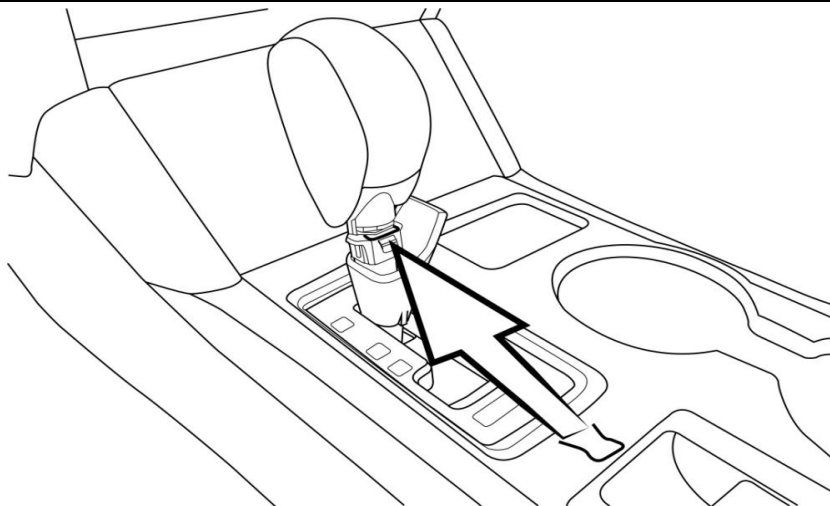

PART NUMBER:  
35160AL00A

ISSUE  
01

4/24/2014

SUBARU OF AMERICA

PAGE  
3/5



**STEP 7: ROTATE CHROME COVER BACK TO ITS ORIGINAL POSITION.**

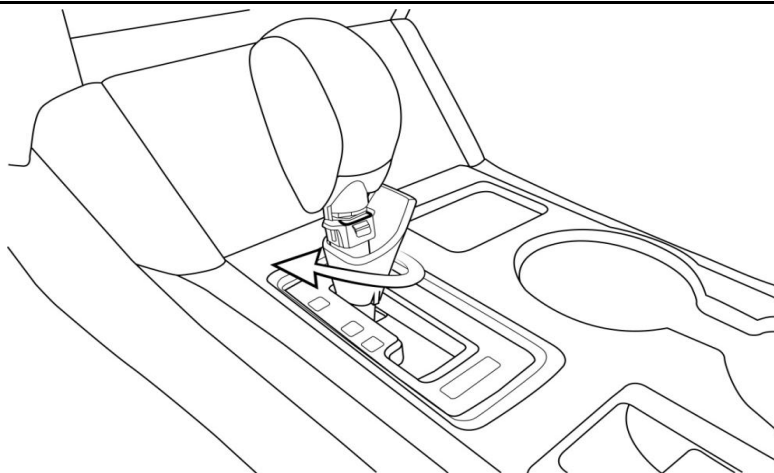

**STEP 8: REINSTALL THE CHROME COVER BY LIFTING UPWARDS UNTIL IT CLICKS INTO PLACE.**

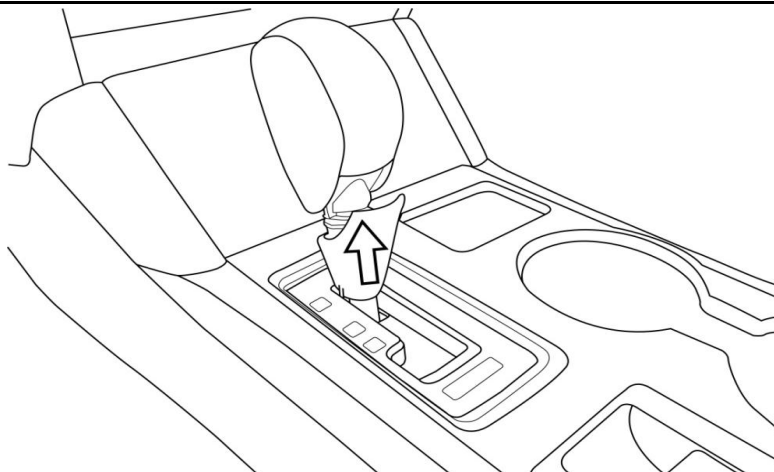

**STEP 9: CONFIRM THAT THE SHIFT KNOB IS FIRMLY INSTALLED AND THAT THE BUTTON CAN BE FULLY DEPRESSED. MAKE SURE THE SHIFT KNOB IS PROPERLY INSTALLED BEFORE OPERATING THE VEHICLE. TURN ON IGNITION, DEPRESS AND HOLD BRAKE PEDAL, CONFIRM SHIFT LEVER CANNOT SHIFT OUT OF "P" WITHOUT DEPRESSING BUTTON.**

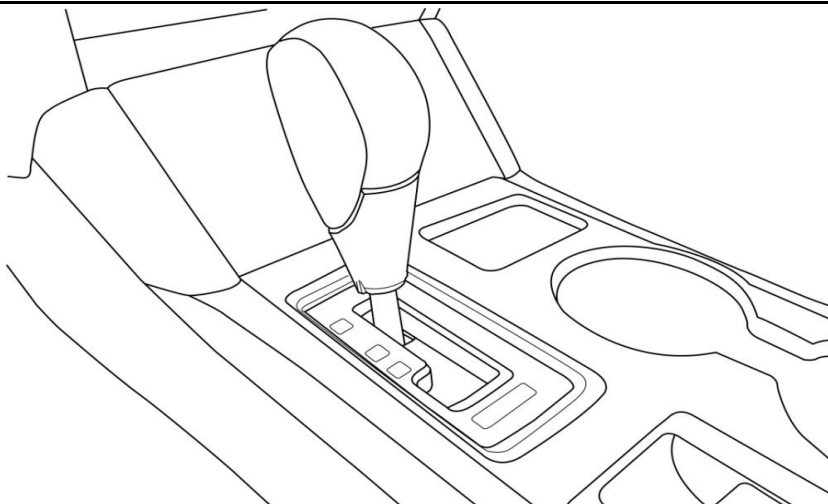



**SUBARU**

**PART NUMBER: 35160AL00A**

**INSTRUCTIONS FOR RE-INSTALLING THE SHIFTER ROD ONLY IF ACCIDENTALLY REMOVED:** RE-INSERT THE SHIFTER ROD AS SHOWN IN THE FIGURE BELOW WITH THE GROOVE FACING LEFT TO RIGHT ON THE VEHICLE.

WHEN CORRECTLY INSTALLED, THE SHIFTER ROD WILL PROTRUDE APPROXIMATELY 19MM-20MM (0.75" - 0.79"). WHEN IMPROPERLY INSTALLED, THE SHIFTER ROD WILL PROTRUDE APPROXIMATELY 26MM - 29MM (1.02" - 1.14").

**CAUTION: INCORRECTLY INSTALLING THE SHIFTER WITH THE GROOVE FACING FORWARD AND BACK MAY MAKE IT POSSIBLE TO SHIFT INTO OTHER GEAR RANGES WITHOUT HOLDING DOWN THE SHIFTER BUTTON.**

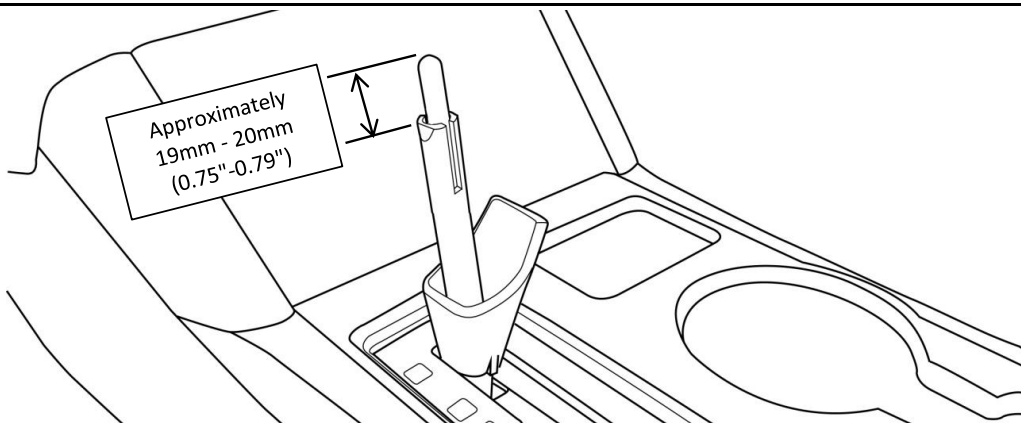
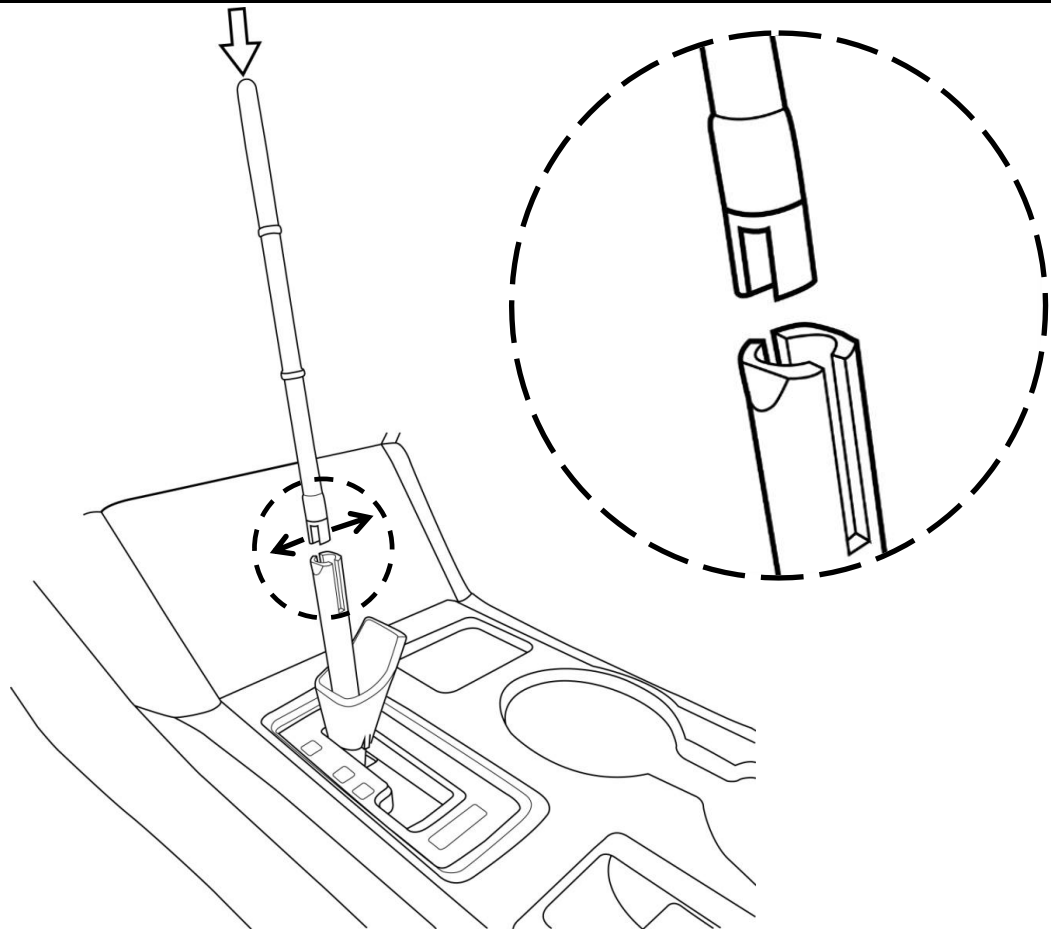

PART NUMBER:  
35160AL00A

ISSUE  
01

4/24/2014

SUBARU OF AMERICA

PAGE  
5/5